

# Control of an Induction Motor Driving a Flexible-Robot for Trajectory Tracking<sup>★</sup>

Felipe J. Torres<sup>\*</sup> Juan P. Ramírez<sup>\*</sup> Ricardo Zavala-Yoe<sup>\*\*</sup>  
Gerardo V. Guerrero<sup>\*\*\*</sup> Carlos D. García<sup>\*\*\*</sup> Juan Mota<sup>\*\*\*\*</sup>

<sup>\*</sup> *University of Guanajuato, Salamanca, Guanajuato, CP 36885, México (e-mail: fdj.torres@ugto.mx, jpi.ramirez@ugto.mx).*

<sup>\*\*</sup> *Monterrey Institute of Technology and Higher Education, CDMX, CP 14380, México (e-mail: rzavalay@itesm.mx)*

<sup>\*\*\*</sup> *TecNM/CENIDET, Cuernavaca, Morelos, CP 62490, México (e-mail: gerardog@cenidet.edu.mx, cgarcia@cenidet.edu.mx)*

<sup>\*\*\*\*</sup> *Polytechnic University of Guerrero State, Taxco, Guerrero, CP 40321, México (e-mail: jmota@upeg.edu.mx)*

---

**Abstract:** This work presents a tracking control of a Flexible-Robot being actuated by a three phase induction motor, assuming a system control without perturbation and the case where a periodic pulse perturbation input is applied. Previous research about Flexible-Robot consider a dc motor to drive the joint. Induction Motors depict an alternative to be used as actuator, their main advantage is due to the minor cost in both the purchase and maintenance, but their nonlinear dynamics to set control is a challenge. The dynamic model of a joint-flexible-robot is combined with the induction motor dynamics. A control law is introduced to track a desired trajectory. This control input is used like the reference torque for the induction motor. Through the Simpson's 1/3 rule, the gain tuning for the tracking controller is given by minimizing the integral of time-weighted absolute error (ITAE). Simulations show the effectiveness of the controller proposed.

*Keywords:* Induction motors, flexible robots, nonlinear control systems, manipulators, tuning.

---

## 1. INTRODUCTION

The robot manipulators have been a research interest during last three decades. The most of the studies have been based on the rigid manipulators, however some works point to unreal dynamics of rigid manipulators due to the flexural effects. Thus, Kalyoncu (2008) notes that the flexible manipulators undergo a combination of rigid and flexible motions. In this manner, in De Luca (2000) control laws for tracking tasks are designed on the basis of more complete dynamic models including deflections in the robot components for a one-link flexible arm. In Arteaga and Siciliano (2000), the tracking control problem of flexible robot arms is addressed, improving the damping of the system through the robust control techniques where the whole state is available. In Ji et al. (2008), the linear quadratic Gaussian method from the optimal control theory is developed in combination with a input-estimation algorithm to enhance the ability of disturbance torque input estimation in the joint control of a flexible-joint robot system.

Recently, intelligent control methods have been used to track a desired trajectory of a single-link flexible structure. For instance, Sun et al. (2018) develops a fuzzy neural network (NN) control based on the discrete dynamic model. Yang and Tan (2018) designs a sliding mode boundary controller for a single flexible-link manipulator based on adaptive radial basis function (RBF) neural network.

All of these studies consider a common assumption: they employ a DC-motor as actuator. In Tokhi and Azad (2008), a considerable amount of research on the flexible manipulators is covered, all of them consider DC-motor to drive the flexible manipulator.

The main handicap of the DC-motors is given by their highly cost due to the use of rare-earth (neodymium-iron-boron or samarium-cobalt) in the permanent magnet production. Front of this problematic, induction motors (IM) are an alternative, because they offer low cost of manufacturing and high output torque. IM's have a strong disadvantage, which is set by the difficulty to get control, caused by their nonlinear dynamics. In this sense, researches has been reported on coupling of induction motors and rigid robot manipulators to track a desired

---

<sup>★</sup> This work was supported by the PRODEP-2018 program of México.

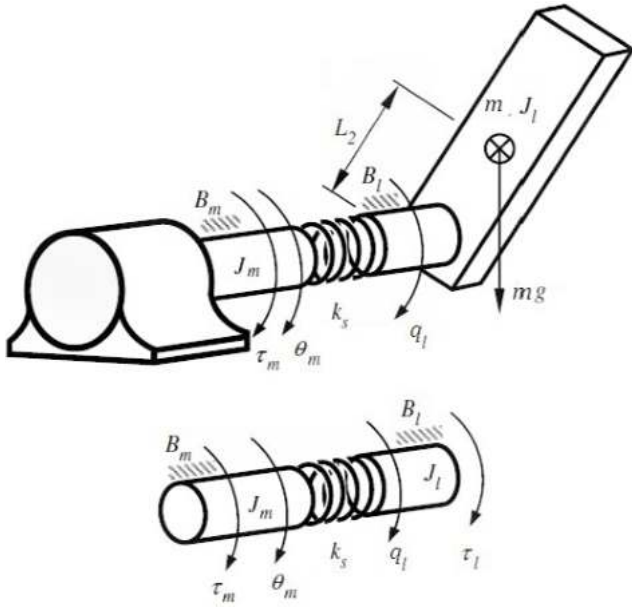

Fig. 1. One-link flexible robot driven by an induction motor

trajectory in Hu et al. (1996), Guerrero-Ramírez and Tang (2001) and de Diniz et al. (2012).

In this paper, the trajectory tracking control of a one-link flexible robot driven by a three phase induction motor is studied for the case when the system control is affected by a periodic pulse perturbation. The controller proposed to achieve tracking is used like the reference torque for the induction motor control and, thereby, the angular position of the link  $q_l$  tracks the desired angular position  $\theta_d$  by means of the spring coupling attached to the angular position of the induction motor  $\theta_m$ .

## 2. DYNAMIC MODELS

### 2.1 Dynamic Model of the Flexible Robot

Consider a one-link flexible robot driven by an induction motor given in Fig. 1. Based on Ji et al. (2008), the dynamical equations of motion result in:

$$J_l \ddot{q}_l(t) + B_l \dot{q}_l(t) + k_s [q_l(t) - \theta_m(t)] + mgL \sin(q_l(t)) = 0, \quad (1)$$

$$J_m \ddot{\theta}_m(t) + B_m \dot{\theta}_m(t) - k_s [q_l(t) - \theta_m(t)] = \tau_m, \quad (2)$$

where  $J_m$  is the motor inertia,  $J_l$  is the link inertia,  $k_s$  is the torsional spring constant,  $m$  is the link mass,  $L$  is the distance to the centre of mass of link,  $\theta_m$  is the motor angular displacement,  $B_m$  is the motor viscous coefficient,  $B_l$  is the link viscous coefficient, and  $q_l$  is the link angular displacement.  $\tau_m$  represents the motor electromagnetic torque, which is provided by a three-phase induction motor.

### 2.2 Dynamic Model of the Induction Motor

The current  $i_\alpha - i_\beta$  and flow  $\lambda_\alpha - \lambda_\beta$  vectors of the stationary reference frame fixed to the stator  $\alpha - \beta$  of the induction motor, are used to express the equations in a field-oriented frame  $d - q$ . In this sense, the model of the IM mechanical and electrical dynamics without to consider the effects of viscous friction, is given by Marino et al. (2010):

$$\begin{aligned} \frac{d\omega_m}{dt} &= \mu \lambda_d i_q - \frac{T_L}{J}, \\ \frac{d\lambda_d}{dt} &= -\alpha \lambda_d + \alpha L_m i_d, \\ \frac{di_d}{dt} &= -\gamma i_d + \alpha \beta \lambda_d + n_p \omega_m i_q + \alpha L_m \frac{i_q^2}{\lambda_d} + \frac{1}{\sigma L_s} u_d, \\ \frac{di_q}{dt} &= -\gamma i_q - \beta n_p \omega_m \lambda_d - n_p \omega_m i_d - \alpha L_m \frac{i_q i_d}{\lambda_d} + \frac{1}{\sigma L_s} u_q, \\ \frac{d\rho}{dt} &= n_p \omega_m + \alpha L_m \frac{i_q}{\lambda_d}, \end{aligned} \quad (3)$$

where  $\rho = \arctan \frac{\lambda_\beta}{\lambda_\alpha}$ ,  $\mu = \frac{3}{2} n_p \frac{L_m}{J L_r}$ ,  $\alpha = \frac{R_r}{L_r}$ ,  $\sigma = \left(1 - \frac{L_m^2}{L_s L_r}\right)$ ,  $\beta = \frac{L_m}{\sigma L_s L_r}$ ,  $\gamma = \frac{R_s L_r^2 + R_r L_m^2}{\sigma L_s L_r^2}$ .  $\omega_m$  is the rotor speed,  $i_d$  and  $i_q$  are the currents on  $d$  axis and  $q$  axis;  $\lambda_d$  is the rotor flux linkage on  $d$  axis.  $T_L$  and  $n_p$  are the load torque and number of pole pairs.  $J$  is the moment of inertia, which is defined constant.  $L_m$  is the mutual inductance;  $L_s$  and  $L_r$  are the self-inductance of the stator and rotor.  $f$  is the nominal frequency in Hertz (Hz).  $R_s$  and  $R_r$  are the resistance of stator and rotor in  $\Omega$ . For last,  $u_d$  and  $u_q$  are the non-linear state feedback control inputs, described by

$$\begin{pmatrix} u_d \\ u_q \end{pmatrix} = \sigma L_s \begin{pmatrix} -n_p \omega_m i_q - \alpha L_m \frac{i_q^2}{\lambda_d} - \alpha \beta \lambda_d + v_d \\ n_p \beta \omega_m \lambda_d + n_p \omega_m i_d + \alpha L_m \frac{i_d i_q}{\lambda_d} + v_q \end{pmatrix}. \quad (4)$$

Applying equation (4) to the model equation (3), the next closed-loop system is obtained

$$\begin{aligned} \frac{d\omega_m}{dt} &= \mu \lambda_d i_q - \frac{T_L}{J}, \\ \frac{d\lambda_d}{dt} &= -\alpha \lambda_d + \alpha L_m i_d, \\ \frac{di_d}{dt} &= -\gamma i_d + v_d, \\ \frac{di_q}{dt} &= -\gamma i_q + v_q, \\ \frac{d\rho}{dt} &= n_p \omega_m + \alpha L_m \frac{i_q}{\lambda_d}, \end{aligned} \quad (5)$$

where  $v_d$  and  $v_q$  are the new control inputs, which are obtained by applying PI loops

$$v_d = K_{d1} (\lambda_{dref} - \lambda_d) + K_{d2} \int (\lambda_{dref} - \lambda_d) dt, \quad (6)$$

$$v_q = K_{q1} (T_{ref} - \tau_m) + K_{q2} \int (T_{ref} - \tau_m) dt, \quad (7)$$

$$T_{ref} = K_{\tau 1} (\omega_{ref} - \omega_m) + K_{\tau 2} \int (\omega_{ref} - \omega_m) dt, \quad (8)$$

where  $\lambda_{dref}$ ,  $T_{ref}$  and  $\omega_{ref}$  are the references for rotor flux linkage, torque and angular speed, respectively.  $K_{d1}$ ,  $K_{d2}$ ,  $K_{q1}$ ,  $K_{q2}$ ,  $K_{\tau 1}$  and  $K_{\tau 2}$  are positive constant gains. From equation (2),  $\tau_m$  is the electromagnetic torque, which is defined as  $\tau_m = \mu J \lambda_d i_q$ .

### 3. TRACKING CONTROL STRATEGY

Based on Arteaga and Siciliano (2000), the tracking errors in relation with the link, are defined as:

$$\tilde{q}_l = q_l - q_d, \quad (9)$$

$$\dot{\tilde{q}}_l = \dot{q}_l - \dot{q}_d, \quad (10)$$

$$\dot{q}_{lr} = \dot{q}_d - \Lambda \tilde{q}_l, \quad (11)$$

$$\ddot{q}_{lr} = \ddot{q}_d - \Lambda \dot{\tilde{q}}_l, \quad (12)$$

$$s_l = \dot{q}_l - \dot{q}_{lr}, \quad (13)$$

$$s_l = \dot{q}_l - \dot{q}_{lr}, \quad (14)$$

where  $q_d$  is the desired trajectory,  $\Lambda$  is a positive-definite and diagonal matrix.

The tracking errors with relation to the induction motor, are given by:

$$\tilde{\theta}_m = \theta_m - q_d, \quad (15)$$

$$\dot{\tilde{\theta}}_m = \dot{\theta}_m - \dot{q}_d, \quad (16)$$

$$\dot{\theta}_{mr} = \dot{q}_d - \Lambda \tilde{\theta}_m, \quad (17)$$

$$\ddot{\theta}_{mr} = \ddot{q}_d - \Lambda \dot{\tilde{\theta}}_m, \quad (18)$$

$$s_m = \dot{\theta}_m - \dot{\theta}_{mr}. \quad (19)$$

$$s_m = \dot{\theta}_m - \dot{\theta}_{mr}. \quad (20)$$

The controller proposed to track the desired trajectory is given by:

$$u = J_l \ddot{q}_{lr} + B_l \dot{q}_{lr} + mgL \sin(q_l) + K_e \tilde{q}_l - K_p s_l - K_p s_m, \quad (21)$$

where  $K_e$  and  $K_p$  are positive-definite and diagonal matrices.

**Assumption.** The tracking control law given in equation (21) is the reference torque  $T_{ref}$  for the induction motor control loop in equation (7).

This assumption points to delete the PI Loop equation (8) from the induction motor control. The complete control scheme is shown in Fig. 2.

### 4. RESULTS

The proposed controller is proved by simulation through the *Simulink*<sup>®</sup> platform using the S-function level-2 with ode-45 solver, variable-step, and simulation time of 10 seconds. The induction motor parameters are shown in table 1. The parameters of the one-link flexible robot are given in table 2.

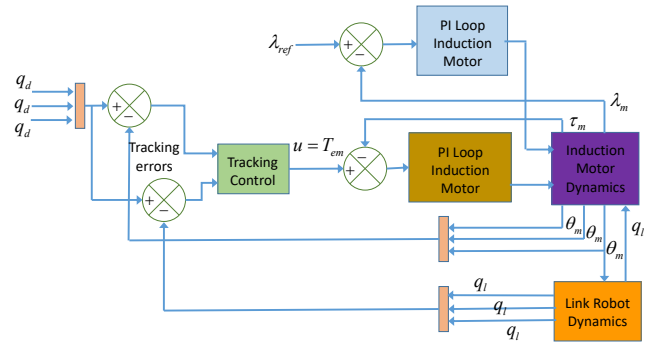

Fig. 2. Tracking control scheme for the one-link flexible robot driven by induction motor

#### 4.1 Gain Tuning

The integral of time-weighted absolute error (ITAE), is the performance index used as objective function in the gain tuning process for the tracking controller. The index ITAE is defined as:

$$ITAE = \int_0^{\infty} t |e(t)| dt \quad (22)$$

where  $t$  is the time and  $e(t)$  is the difference between the desired trajectory and the angular position of the robot link, thus

$$e(t) = q_d - q_l. \quad (23)$$

On each evaluation of the objective function, the model developed in *Simulink*<sup>®</sup> is executed and the ITAE performance index is calculated using the multiple application Simpson's 1/3 rule Martins (2005), resulting in:

$$K_e = 4.6615,$$

$$K_p = 59.2651.$$

The other gains were set arbitrary as:

Table 1. Parameters of the induction motor

Parameter	Value	Parameter	Value
Power	200 W	Poles	4
Speed	1732 rpm	Voltage	220 V 3-phase
$R_s$	1.77 $\Omega$	$R_r$	1.34 $\Omega$
$L_{ls}$	0.024 H	$L_m$	0.245 H
$L_{lr}$	0.013 H	$J_m$	0.025 $kg \cdot m^2$
$B_m$	0.015 $\frac{N \cdot m \cdot s}{rad}$		

Table 2. Parameters of the robot link

Parameter	Value	Parameter	Value
$m$	1 kg	$L$	1 m
$k_s$	5200 $\frac{N \cdot m}{rad}$	$J_l$	0.15 $kg \cdot m^2$
$B_l$	0.015 $\frac{N \cdot m \cdot s}{rad}$		

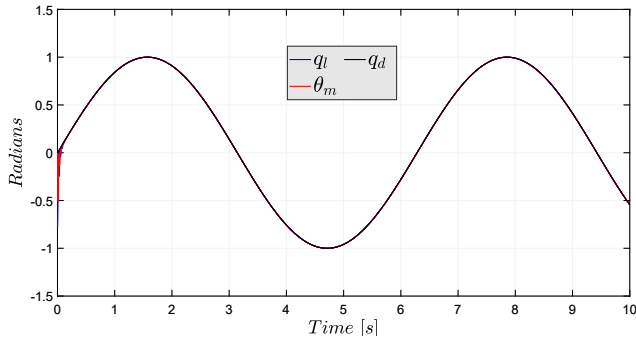

Fig. 3. Tracking control performance for the one-link flexible robot driven by induction motor.

$$\begin{aligned} K_{d1} &= 200, \\ K_{d2} &= 800, \\ K_{q1} &= 800, \\ K_{q2} &= 1300, \\ \Lambda &= 40. \end{aligned}$$

#### 4.2 Reference Data

The desired trajectory is given by:

$$q_d = \sin(t). \quad (24)$$

The reference flux linkage for the motor control is set as

$$\lambda_{ref} = 0.4 \text{ Wb}.$$

The initial position for the one-link flexible robot and the desired trajectory are

$$\begin{aligned} q_l(0) &= -\frac{\pi}{4} \text{ rad}, \\ q_d(0) &= 0 \text{ rad}. \end{aligned}$$

#### 4.3 Case a. Tracking control without a perturbation input

The results of the simulations, assuming that the control system is without a perturbation input, are shown in Fig. 3, where the black line is used to describe the desired trajectory, blue line is set for the link angular position and the red line represents the induction motor angular position. It is clear to remark that the flexible robot tracks the desired trajectory while the rotor angular position of the induction motor drive the one-link. Also, it is noted a transient response at the beginning of the tracking performance, this is shown in Fig. 4.

The Fig. 5 produces the error values  $s_l$  with blue color and  $s_m$  with red color, and Fig. 6 displays the induction motor electromagnetic torque with green color and the reference torque with magenta color.

#### 4.4 Case b. Introducing a perturbation input

A perturbation input is introduced to the system control like it is shown in Fig. 7. The perturbation signal is a pulse waveform added to the input control signal (produced

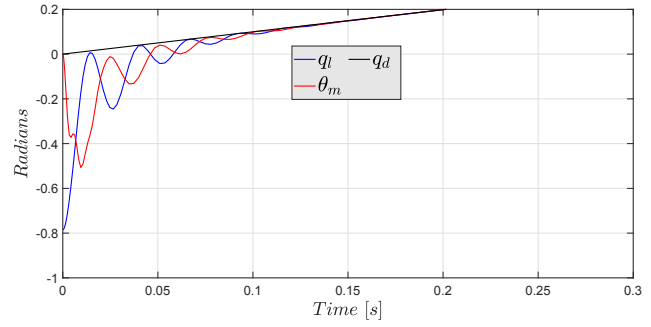

Fig. 4. Zoom in on the transient response for the trajectory tracking.

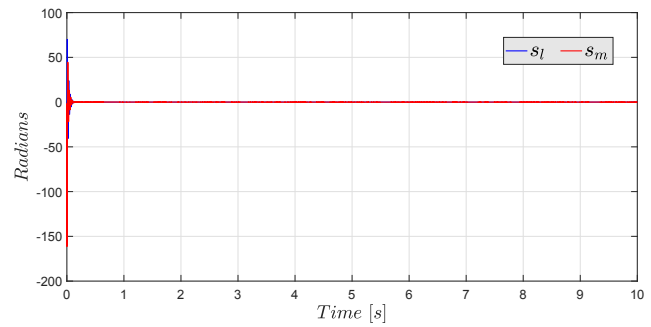

Fig. 5. Tracking errors for the one-link flexible motor driven by induction motor.

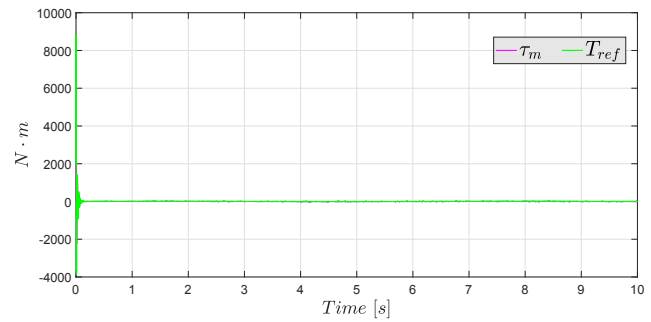

Fig. 6. Electromagnetic torque and reference torque for the induction motor.

by the induction motor PI loops), then they are applied to the system dynamics (induction motor and one-link flexible robot).

The parameters of the pulse perturbation input are given in table 3.

Table 3. Parameters of the pulse perturbation input.

Parameter	Value
Amplitude	1100
Period	3 s
Pulse width	0.2 s
Phase delay	1.5 s

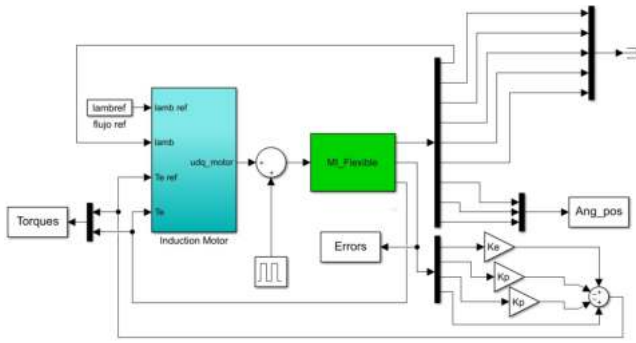

Fig. 7. Block diagram of the system control with a perturbation input.

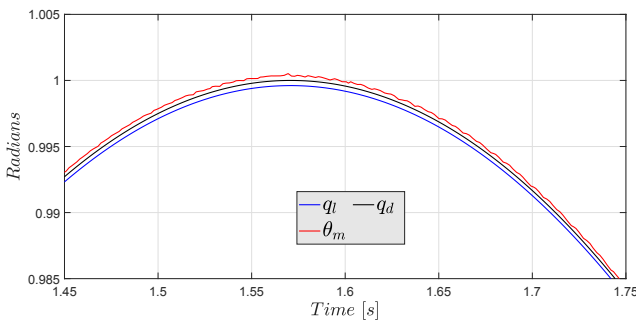

Fig. 8. Zoom in on the trajectory tracking without a perturbation input.

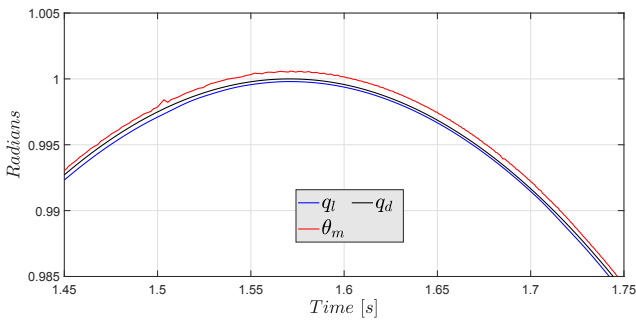

Fig. 9. Zoom in on the trajectory tracking with a perturbation input.

A comparison of the results of the performance of the tracking control introducing a pulse perturbation input versus the system control without perturbation, are shown in Fig. 8 and Fig.9 by means of a zoom in on the same time interval. The difference between these cases is minimum.

Comparisons with respect to the tracking errors are given in Fig. 10 and Fig. 11. The tracking error for the system control with a perturbation input holds an increasing chattering,  $2.0 < t < 2.3$  and  $5.0 < t < 5.3$  s, after the pulse perturbation is applied,  $1.5 < t < 1.7$  and  $4.5 < t < 4.7$  s.

Finally, Fig. 12 and Fig. 13 display the electromagnetic torque without perturbation and the case where a pertur-

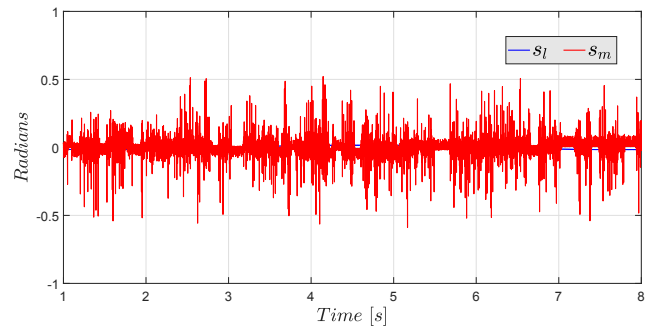

Fig. 10. Zoom in on the tracking errors performance without a perturbation input.

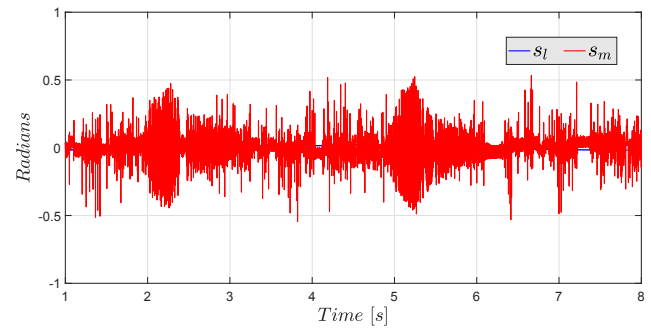

Fig. 11. Zoom in on the tracking errors performance with a perturbation input.

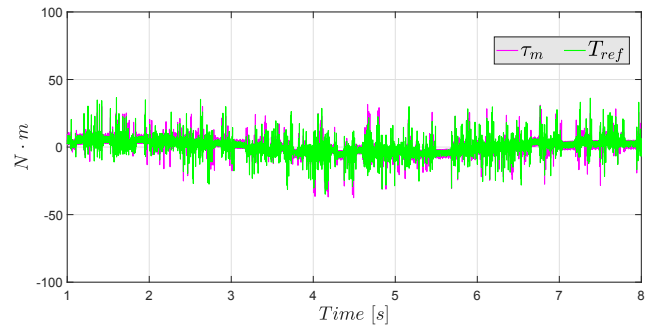

Fig. 12. Zoom in on the torques for the induction motor without a perturbation input.

bation input is applied. Due to the perturbation input is added to the control signal produced by the induction motor, the effect of the pulse perturbation is clear on the time interval  $1.5 < t < 1.7$ ,  $4.5 < t < 4.7$  and  $7.5 < t < 7.7$  s.

## 5. CONCLUSIONS

Flexible robots have been target of research for last years. All of the previous works contemplated the dc motor as actuator. This document has presented an alternative to drive the flexible robot, that is the induction motor. The proposed tracking controller has been taken as the reference torque for the induction motor control. The gains of this control law were tuned by minimizing the

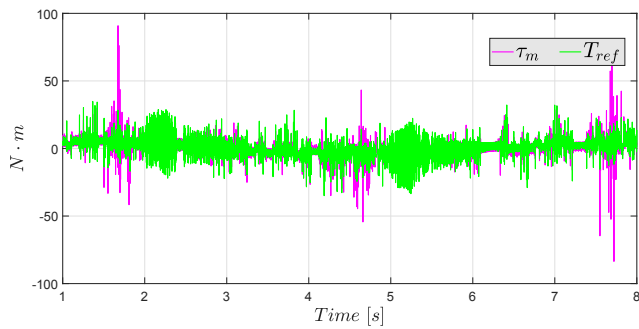

Fig. 13. Zoom in on the torques for the induction motor with a perturbation input.

integral of time-weighted absolute error (ITAE) through the Simpson's 1/3 rule. The simulations for the one-link flexible robot driven by induction motor have shown a convergence to the desired trajectory while the tracking errors are carried to zero for both cases: without a perturbation input and assuming a periodic pulse perturbation input.

#### REFERENCES

- Arteaga, M.A. and Siciliano, B. (2000). On tracking control of flexible robot arms. *IEEE Transactions on Automatic Control*, 45(3), 520–527.
- de Diniz, E., Júnior, A.B., Honório, D.A., Barreto, L.H., and Dos Reis, L.L. (2012). An elbow planar manipulator driven by induction motors using sliding mode control for current loop. *Control and Cybernetics*, 41(2), 395–413.
- De Luca, A. (2000). Feedforward/feedback laws for the control of flexible robots. In *Robotics and Automation, 2000. Proceedings. ICRA '00. IEEE International Conference on*, volume 1, 233–240. IEEE.
- Guerrero-Ramírez, G. and Tang, Y. (2001). Motion control of rigid robots driven by current-fed induction motors. *Mechatronics*, 11(1), 13–25.
- Hu, J., Dawson, D.M., and Qian, Y. (1996). Position tracking control for robot manipulators driven by induction motors without flux measurements. *IEEE Transactions on Robotics and Automation*, 12(3), 419–438.
- Ji, C.Y., Chen, T.C., and Lee, Y.L. (2008). Joint control for flexible-joint robot with input-estimation approach and lqg method. *Optimal Control Applications and Methods*, 29(2), 101–125.
- Kalyoncu, M. (2008). Mathematical modelling and dynamic response of a multi-straight-line path tracking flexible robot manipulator with rotating-prismatic joint. *Applied Mathematical Modelling*, 32(6), 1087–1098.
- Marino, R., Tomei, P., and Verrelli, C.M. (2010). *Induction motor control design*. Springer Science & Business Media.
- Martins, F.G. (2005). Tuning pid controllers using the itae criterion. *International Journal of Engineering Education*, 21(5), 867.
- Sun, C., Gao, H., He, W., and Yu, Y. (2018). Fuzzy neural network control of a flexible robotic manipulator using assumed mode method. *IEEE transactions on neural networks and learning systems*, (99), 1–14.
- Tokhi, M.O. and Azad, A.K. (2008). *Flexible robot manipulators: modelling, simulation and control*, volume 68. Iet.
- Yang, H.J. and Tan, M. (2018). Sliding mode control for flexible-link manipulators based on adaptive neural networks. *International Journal of Automation and Computing*, 15(2), 239–248.